

ADJUSTABLE VACUUM GENERATORS CONEYOR

Working principle

The operation of these vacuum generators is based on the Venturi principle.

Unlike the previous ones, the ejector, apart from having a much larger flow diameter, is also adjustable.

This feature allows modifying the capacity and the vacuum level of the device, without intervening on the air supply pressure level.

Also the compressed air consumption is related to the actual performance of the vacuum generator.

Features

The special shape of these adjustable vacuum generators, as well as their straight-flow working principle allow sucking and transferring products of various nature with no interference, just like flow generators, only, unlike these, they allow overcoming much higher level differences.

They are suited for transferring powders, granulated products, sawdust, metal chips, dry or liquid food products, etc. They are also recommended for controlling vacuum cups in presence of large amounts of dust or liquids, as well as for sucking fumes, cooling mists, water and oil condensation, etc. The absence of moving parts allows for a continuous use without developing heat.

The noise level, which is quite high for this kind of equipment, can be considerably reduced with a silencer screwed on the exhaust connection.

They do not require electricity, therefore, they can even be used in work environments with hazardous environments where an ignition source would be dangerous.

Available in anodised aluminium and stainless steel.

Thanks to all these features, a good filtration of the compressed air supply will be sufficient to make these devices fully maintenance-free.

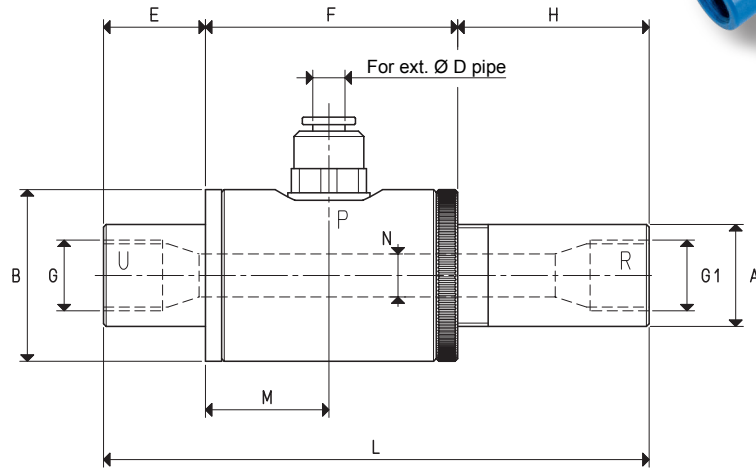

P=COMPRESSED AIR CONNECTION

R=EXHAUST

U=VACUUM CONNECTION

Art.		PVR 25	PVR 50
Max quantità di aria aspirata a 5 bar (g)	cum/h	13.0	36.0
Max. quantity of blown air at 6 bar (g)	cum/h	33.5	88.0
Max. vacuum level	-KPa	80	75
Final pressure	mbar abs.	200	250
Max pressione di alimentazione	bar (g)	6	6
Air consumption at 6 bar (g)	NI/s	6.1	15.5
Working temperature	°C	-20 / +80	-20 / +80
Noise level	dB(A)	92	98
Weight	g	150	280
A	Ø	19	26
B	Ø	32	38
D	Ø	6	8
E		19	35
F		47	54
G	Ø	G1/4"	G3/8"
G1	Ø	G1/4"	G1/2"
H		34	61
L		100	150
M		22	25
N	Ø	6	10

Note:All the vacuum data indicated in the table are valid at the normal atmospheric pressure of 1013 mbar and are obtained with a constant supply pressure.

By adding the letter I to the article, the generator will be supplied in the stainless steel version (E.g.: PVR 50 I).

3D drawing available at www.vuototecnica.net

8.86

Conversion ratio: inch = $\frac{\text{mm}}{25.4}$; pounds = $\frac{\text{g}}{453.6} = \frac{\text{Kg}}{0.4536}$

GAS-NPT thread adapters available at page 1.117

ADJUSTABLE VACUUM GENERATORS CONEYOR PVR 25 and PVR 50

Quantity of sucked air (cum/h) at different supply pressures (bar)

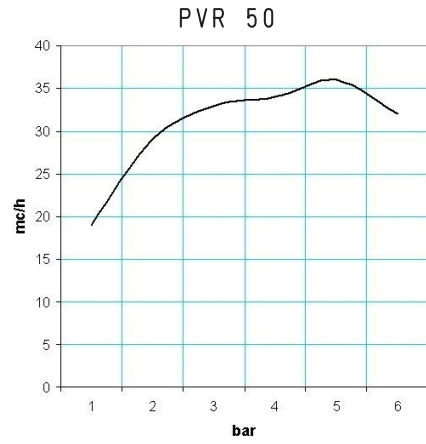
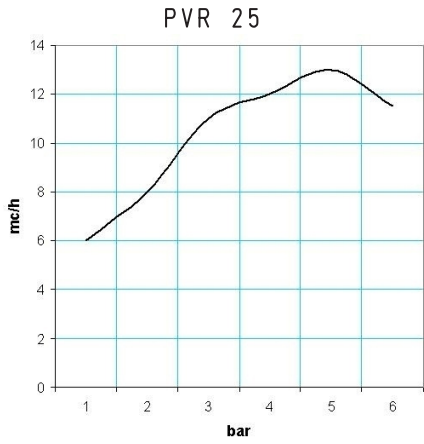

Quantity of blown air (cum/h) at different supply pressures (bar)

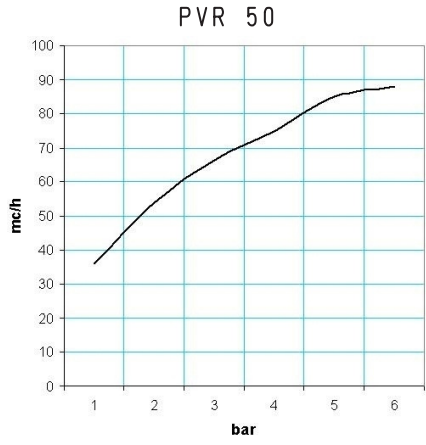
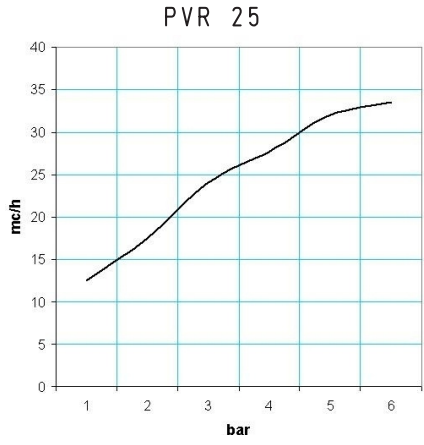

Vacuum level (-Kpa) at different supply pressures (bar)

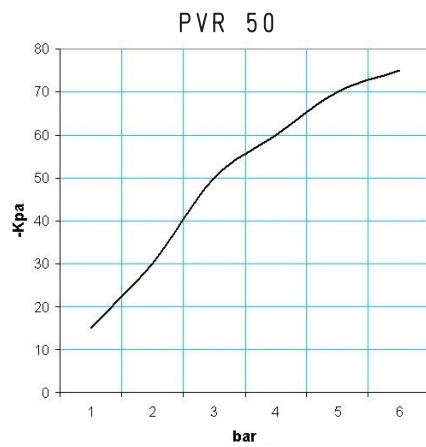
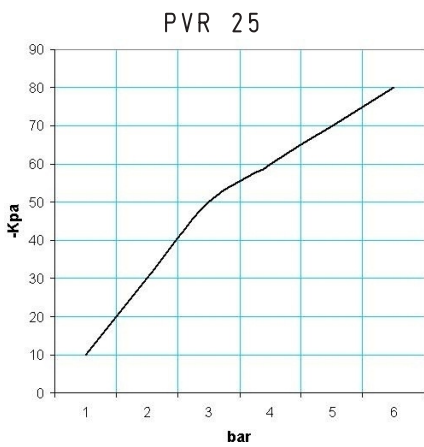

Air consumption (NI/s) at different supply pressures (bar)

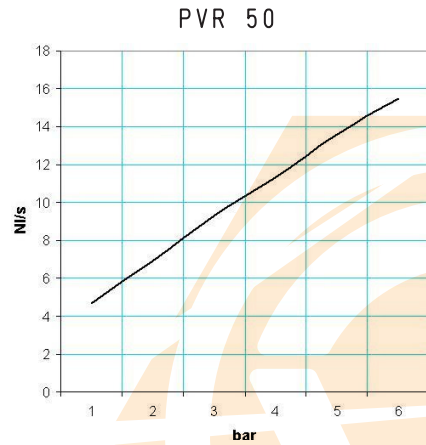
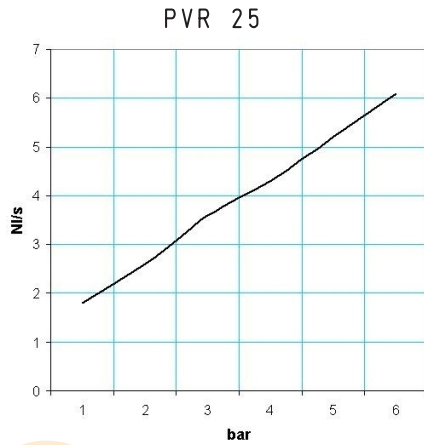

ADJUSTABLE VACUUM GENERATORS CONEYOR PVR 100 and PVR 200

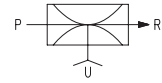
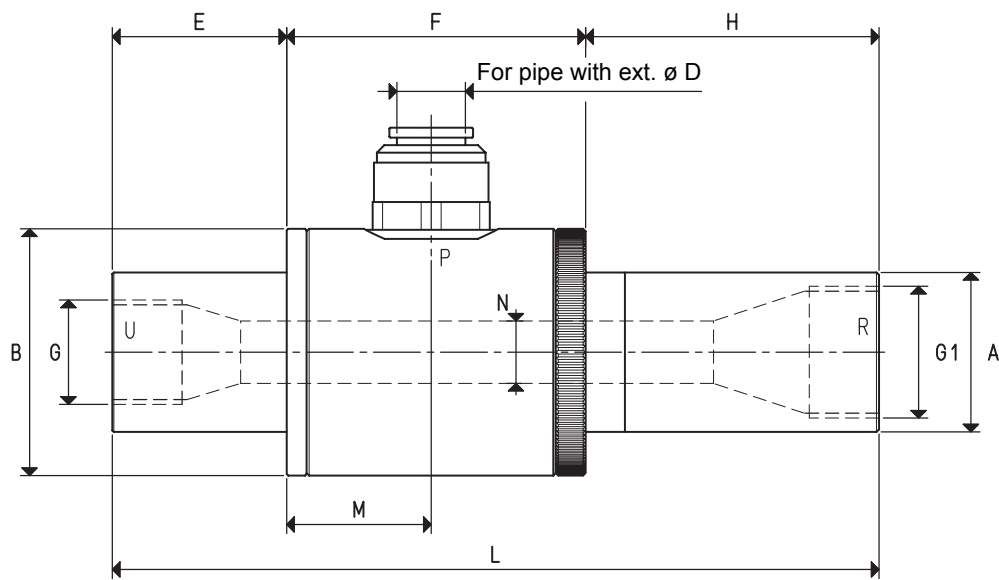

	P=COMPRESSED AIR CONNECTION	R=EXHAUST	U=VACUUM CONNECTION	PVR 100	PVR 200
Art.					
Max quantità di aria aspirata a 5 bar (g)		cum/h		50	72
Max. quantity of blown air at 6 bar (g)		cum/h		129	177
Max. vacuum level		-KPa		75	70
Final pressure		mbar abs.		250	300
Max pressione di alimentazione		bar (g)		6	6
Air consumption at 6 bar (g)		NI/s		22.7	28.3
Working temperature		°C		-20 / +80	-20 / +80
Noise level		dB(A)		100	104
Weight		g		430	550
A		∅		32	38
B		∅		50	57
D		∅		10	12
E				35	35
F				60	60
G		∅		G1/2"	G3/4"
G1		∅		G3/4"	G1"
H				55	77
L				150	172
M				28	28
N		∅		12.5	16.0

Note: All the vacuum data indicated in the table are valid at the normal atmospheric pressure of 1013 mbar and are obtained with a constant supply pressure.

By adding the letter I to the article, the generator will be supplied in the stainless steel version (E.g.: PVR 100 I).

3D drawing available at www.vuotecnica.net

8.88

Conversion ratio: inch = $\frac{\text{mm}}{25.4}$; pounds = $\frac{\text{g}}{453.6} = \frac{\text{Kg}}{0.4536}$

GAS-NPT thread adapters available at page 1.117

ADJUSTABLE VACUUM GENERATORS CONEYOR, PVR 100 and PVR 200

Quantity of sucked air (cum/h) at different supply pressures (bar)

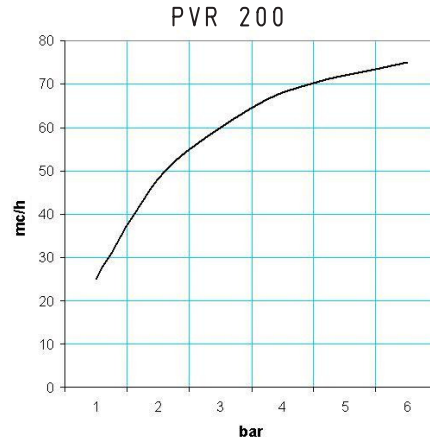
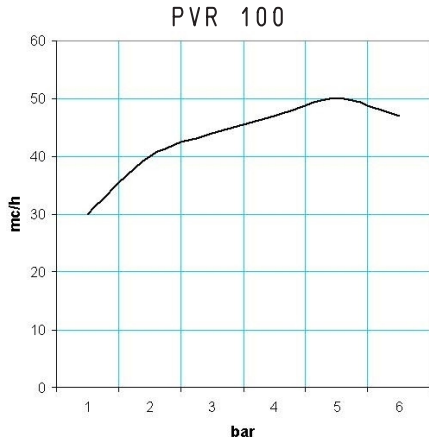

Quantity of blown air (cum/h) at different supply pressures (bar)

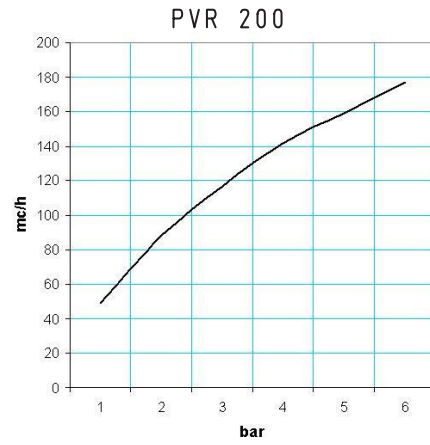
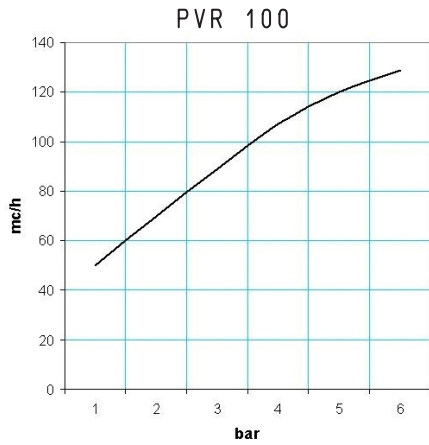

Vacuum level (-Kpa) at different supply pressures (bar)

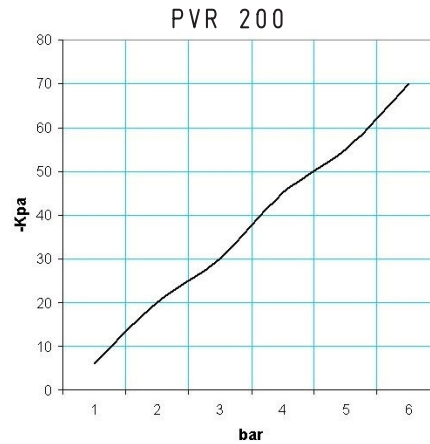
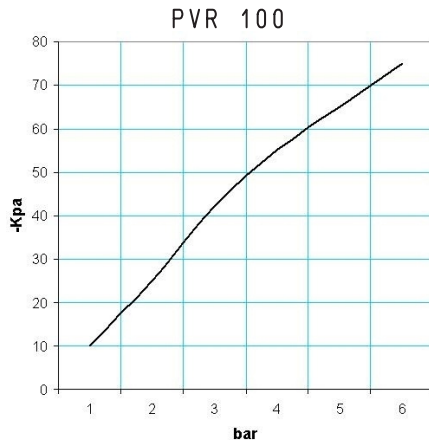

Air consumption (NI/s) at different supply pressures (bar)

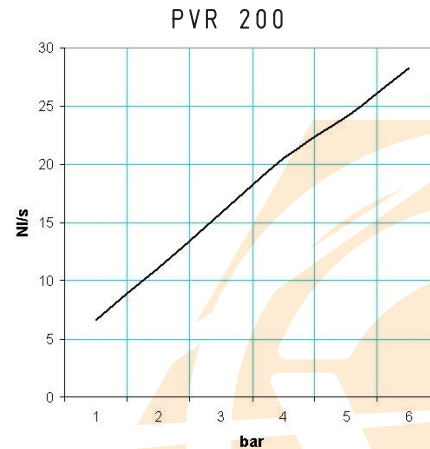
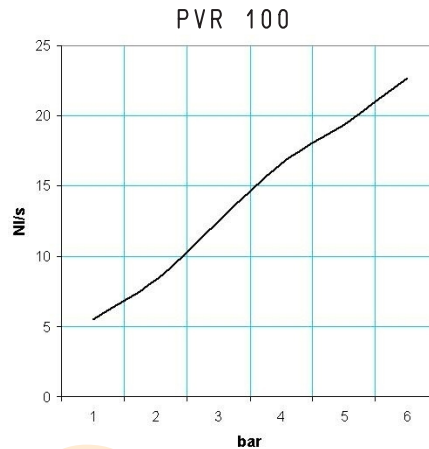

ACCESSORIES FOR ADJUSTABLE VACUUM GENERATORS CONVEYOR

The noise level of adjustable vacuum generators Conveyor is always quite high, but it can be considerably reduced with a silencer screwed on the exhaust connection. Upon request, silencers of the SSX range, which are suitable for any kind of Conveyor vacuum generator, can be supplied.

The table below shows the codes of the silencers associated with the various vacuum generators.

PVR 25 with exhaust silencer SSX 1/4" and vacuum cup 08 53 35 S



PVR 50 with exhaust silencer 2SSX 1/2"



PVR 100 with exhaust silencer SSX 3/4"



Art.	Silencer art.	Noise reduction dB(A)	Silencer art.	Noise reduction dB(A)
PVR 25	SSX 1/4"	-13	2SSX 1/4"	-20
PVR 50	SSX 1/2"	-13	2SSX 1/2"	-20
PVR 100	SSX 3/4"	-13	2SSX 3/4"	-20
PVR 200	SSX 1"	-13	2SSX 1"	-20

8.90